

Smart Radar Level Transmitter

Model: MDRA5



1. Product Overview

1.1 Introduction

MDRA5 radar level transmitter is an 80GHz high-frequency intelligent level measuring instrument, which outputs (4~20) mA analog signals and has a maximum range of up to 35 meters. The antenna is further optimized, and the new fast microprocessor can perform higher-speed signal analysis and processing, so that the instrument can be used for level measurement of liquid storage tanks and solid silos.

1.2 Principle

A radar level transmitter emits a continuous radar wave signal from an antenna. The signal is a frequency modulated continuous wave, or FMCW. There is a frequency difference between the continuous wave emitted from the radar level Transmitter antenna and the echo returned from the surface of the object, the frequency difference is proportional to the distance between the antenna and the surface of the object. After receiving the ECHO, the electronic components are processed by special processing, such as Fourier Transform, and a unique high precision algorithm is used to make the instrument accurately measure the height of the object.

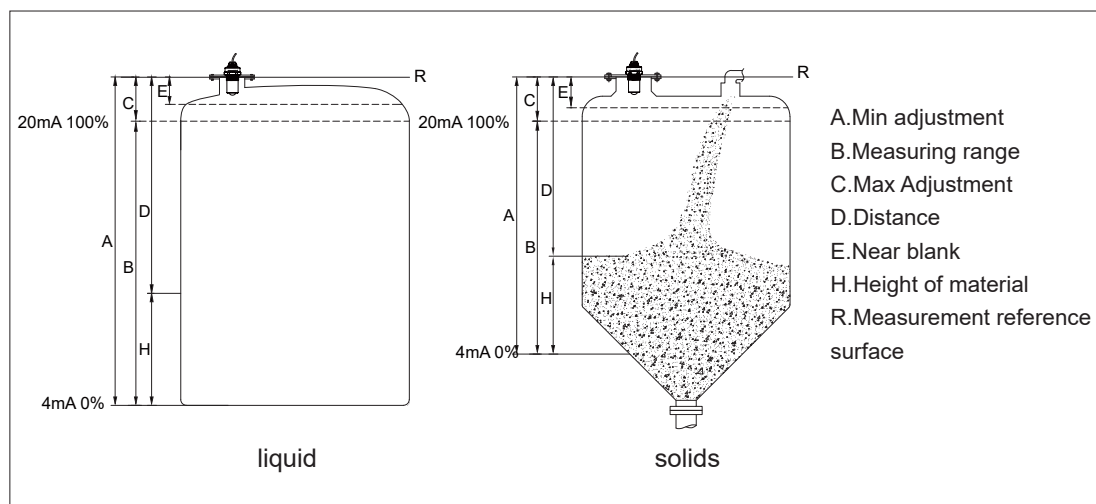

Figure 1

1.3 Characteristics

The radar object level transmitter adopts a working frequency of 80GHz and has the following characteristics:

- ▶ Non-contact measurement, no wear, no pollution.
- ▶ The antenna size is small, easy to install.
- ▶ Shorter wavelength, better reflection on an inclined solid surface.
- ▶ The measuring blind area is smaller, and good results can be obtained for small storage tanks.
- ▶ The small beam angle and concentrated energy enhance the echo ability, and it is beneficial to avoid the

interference.

- ▶ Almost impervious to corrosion and steam.
- ▶ Almost unaffected by changes in temperature and pressure in the atmosphere.
- ▶ And in the serious dust environment the instrument can read the accurate level of the Real Echo.
- ▶ High signal-to-noise ratio, even in the case of fluctuations can also have better performance.
- ▶ 80GHz frequency is the best choice for measuring solid and low dielectric constant media, which is satisfied with the measurement of dielectric constant $\epsilon_r \geq 1.8$.

2.Product introduction

 <p>MDRA5</p>	<p>anti-interference ability, Bluetooth function, small beam angle.</p> <p>Application: suitable for general working conditions, such as:liquid level height measurement in the water industry.</p> <p>Measuring range: 8m/15m/Custom</p> <p>Accuracy: $\pm 2\text{mm}$</p> <p>Blind spot: 0.05m</p> <p>Antenna material:ABS</p> <p>Process connection: G1½"A</p> <p>Install connectionG1"A</p> <p>Process temperature: -40~80°C</p> <p>Process pressure: -0.1~0.3Mpa</p> <p>Frequency Range: 80GHz</p> <p>Bluetooth function: optional</p> <p>Signal output: 4~20mA/24V DC two-wire system 4~20mA/24V DC/HART two-wire system</p> <p>Explosion-proof grade: Exia IIC T6 Ga</p> <p>Protection class: IP68</p>
--	--

3.Installation

Please take note of the following to ensure proper instrument installation.

- ① Please reserve enough space for installation.
- ② Please avoid installation with strong vibration.

3.1 Installation location

- ▶ Install at 1/6 or 1/4 of tank diameter

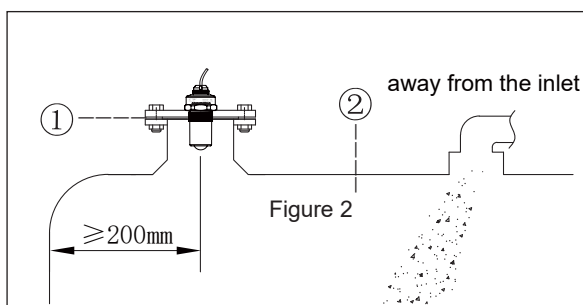

Minimum Distance from tank wall $\geq 200\text{mm}$

Note: ① Datum Plane
② Container Center or symmetrical axis

- The instrument should be mounted in the middle of the tank top if the tank is flat-topped conical tank, to ensure that the bottom of the cone can be measured

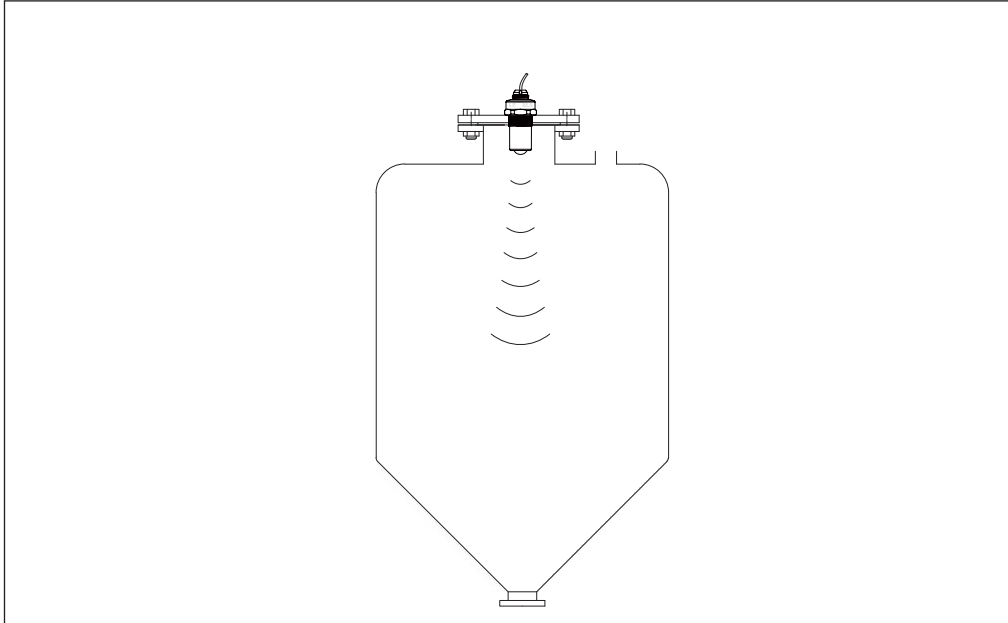
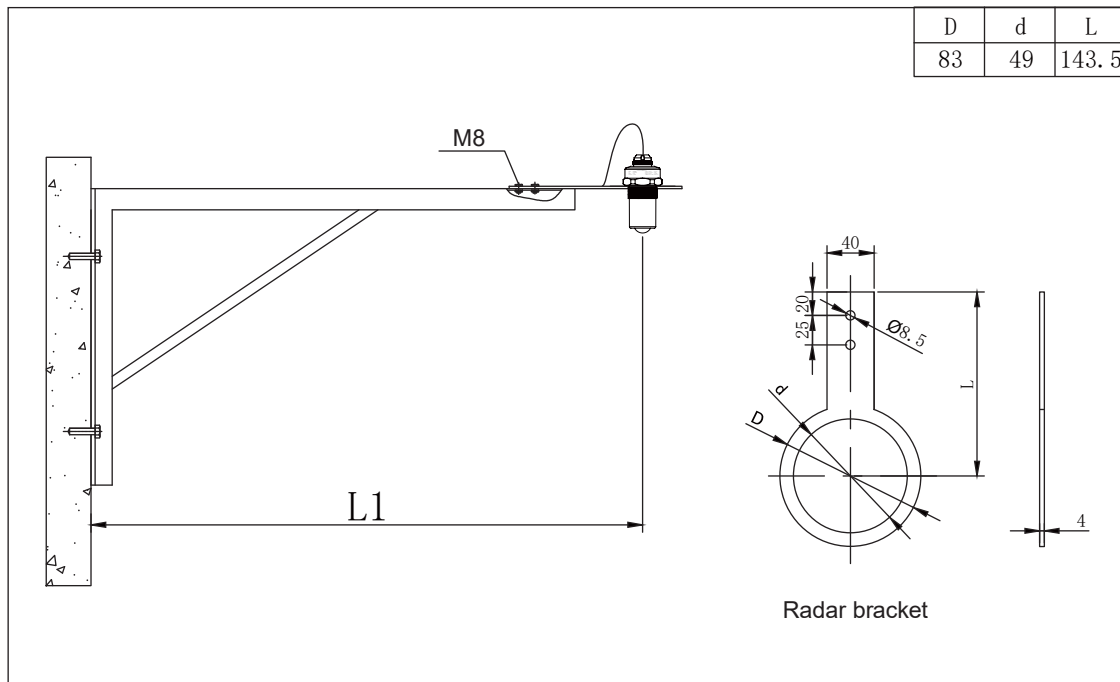

Figure 3

- Bracket mounting



3.2 Typical wrong installation

- It cannot be installed above the inlet.

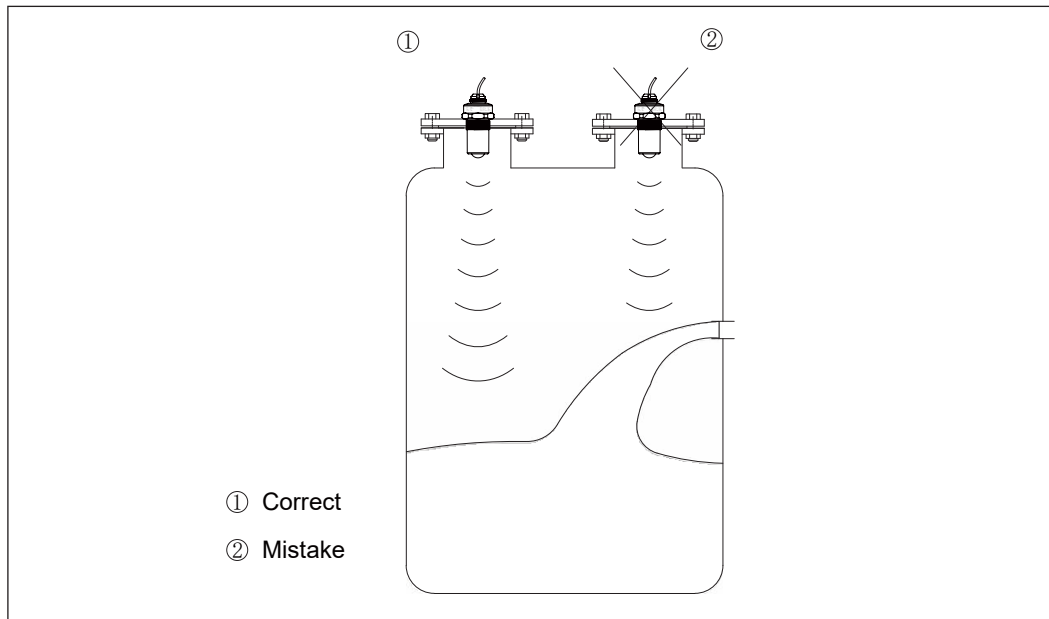

Figure 5

- The instrument cannot be installed in the middle of the arc tank roof, and it will be affected by multiple echoes. Because the curved tank roof can focus multiple echoes, the multiple echoes may be stronger than the true echo signal amplitude, so it cannot be installed in the center position.

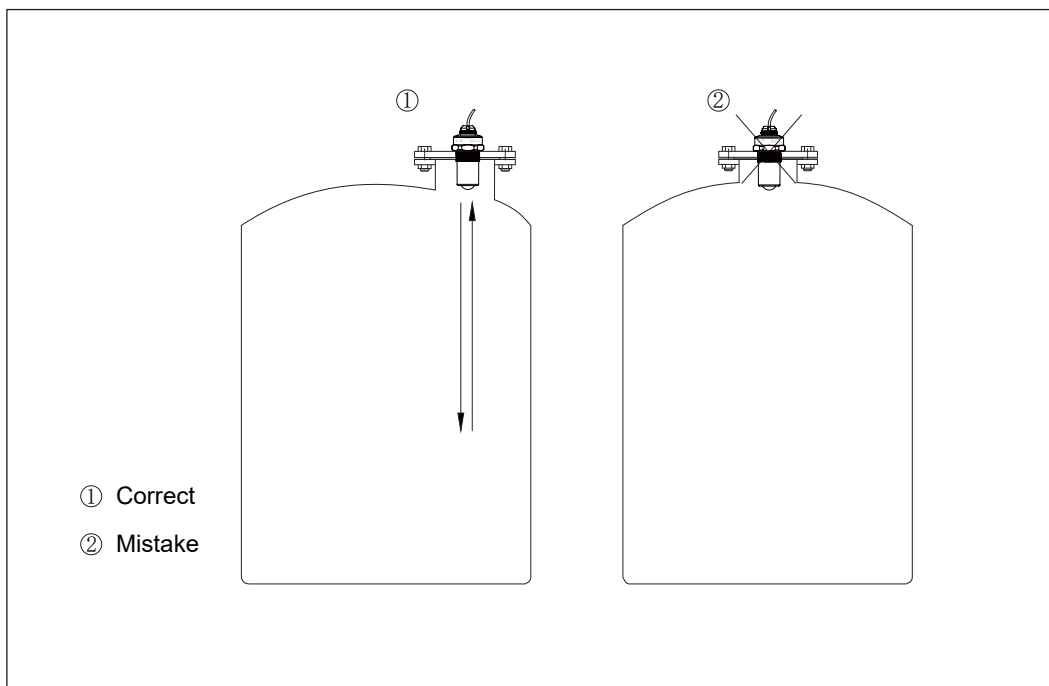

Figure 6

3.3 Tank connection tube

- ▶ It is strongly recommended that the on-site container installation short pipe height is $\leq 200\text{mm}$. It is a very reasonable installation method for the short tube height of the container to be installed less than or equal to 200mm.
- ▶ If the length of the container connection is long, please refer to Figure 7. The longest installation short tube should be smaller than the size shown in Figure 7 as far as possible, and the end must be smoothed without burrs and other protrusions. If necessary, use the "false echo storage" function to eliminate the reflected signal at the end of the tanks nozzle, and you can also obtain better measurement results.

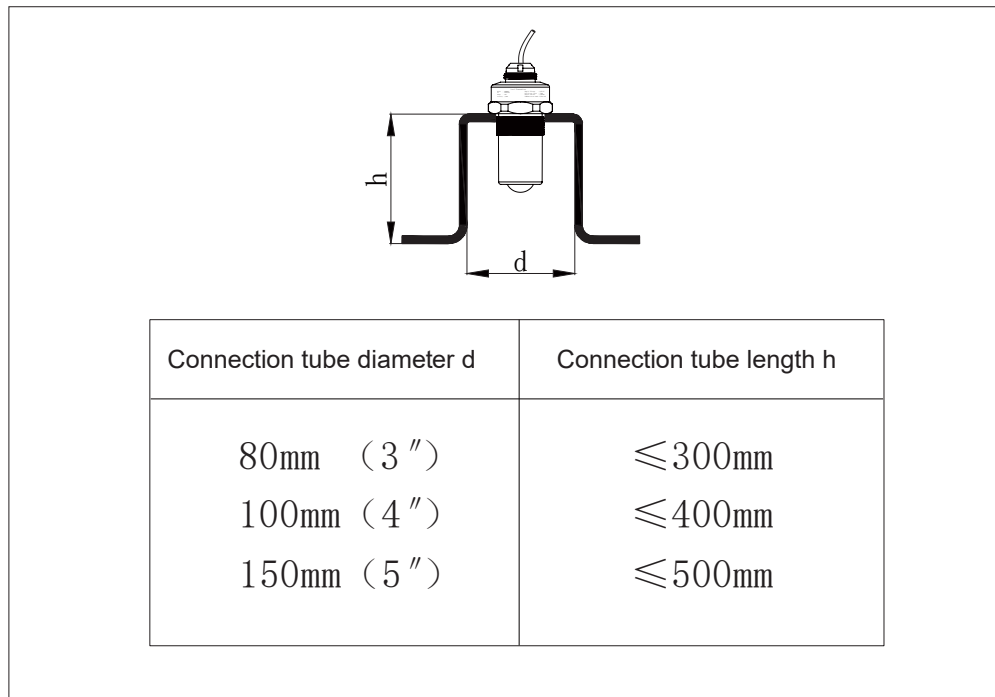

Figure 7

3.4 Launch angle and false reflections

The beam angle of radar level transmitter depends on the size of antenna.

If the radar signal can reach the surface of the medium vertically and there is no device in any container to block and reflect the signal, such measurement conditions are the best.

Be sure to the beam transmit perpendicular to the dielectric surface along the axis of the sensor, and avoid any device in the whole beam angle, especially in the nearest 1 / 3 area from the antenna.

For the far false reflector, the energy of the radar signal is scattered over a large area, so the reflected false signal is very weak and will not have a great impact on the measurement like the near. false echo.

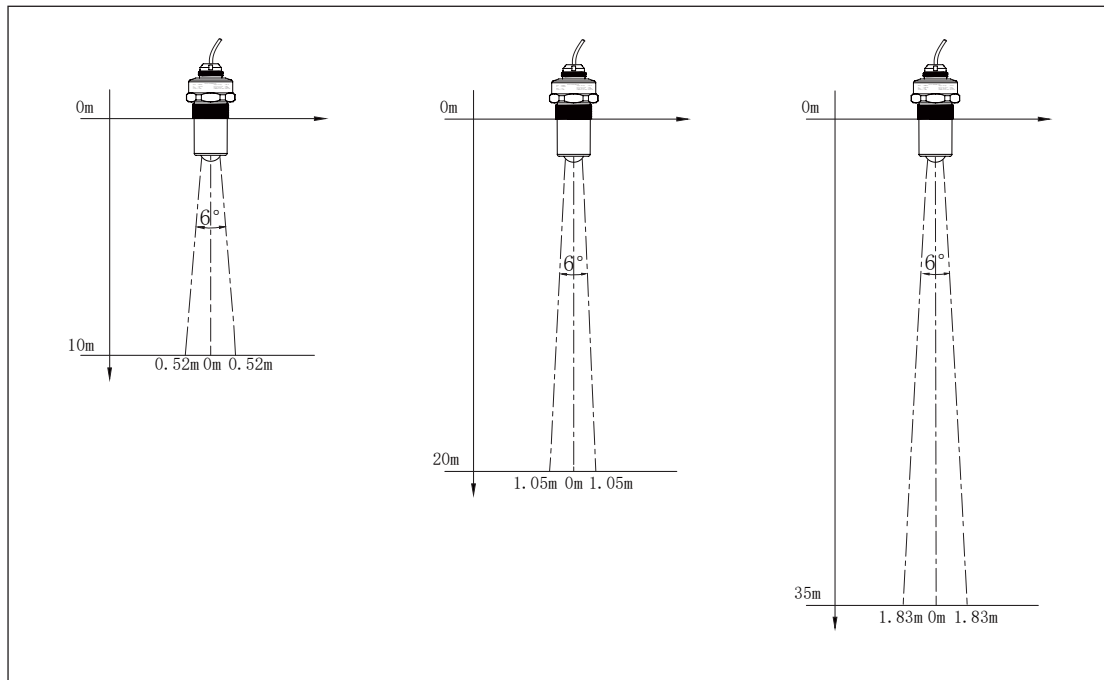

Figure 8

4. Electrical connection

4.1 Supply voltage

The power supply and the output current signal share a two-core shielded cable. For the intrinsically safe type, a safety barrier must be added between the power supply and the instrument.

4.2 Installation of connecting cables

Cable diameter: 6mm. Generally, shielded cables are used for wiring.

4~20mA/HART (two-wire system) power supply cable can use two-core cable.

4.3 Cables shielding and connection

Ideally, the shield is grounded at both ends. However, it should be noted that there will be ground compensation current passing through.

When both ends are grounded, a capacitor with ground potential can be connected to the grounded end (for example: inside the switch cabinet). (eg: 1 μ F; 1500V).

Use a ground with the lowest resistance possible.

(Note: If the instrument is used in the explosion-proof area, due to the potential output, it must not be grounded at both ends)

4.4 Wiring mode

(1) Wiring mode of intrinsically safe single-cavity instrument

24VDC power supply, 4 ~ 20mA output

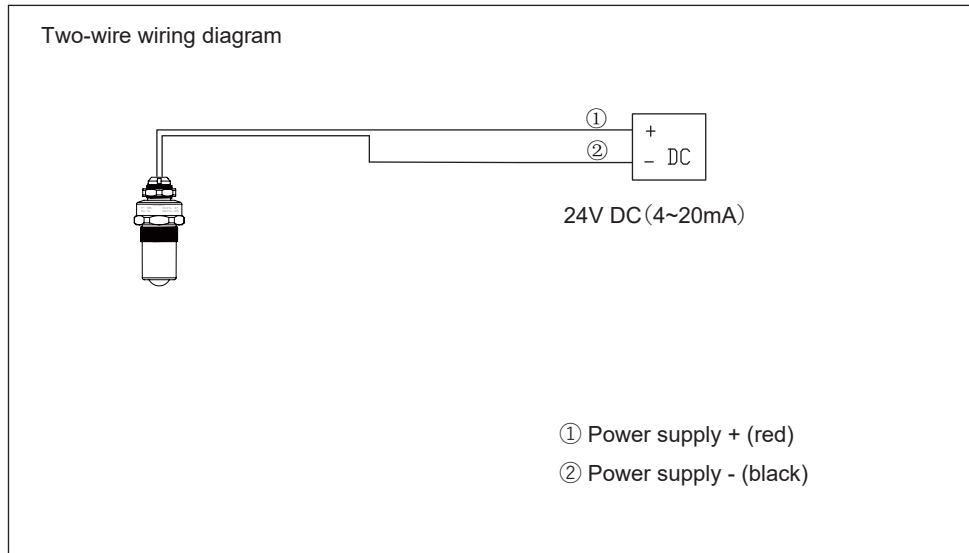

Figure 9

Explosion proof joint:

The explosion-proof type of this product is intrinsically safe. EXPLOSION-PROOF MARK: Exia IIC T6 Ga, this product is suitable for Exia IIC T6 Ga explosion-proof class below the combustible medium level continuous measurement.

This product must be supplied with safety grille when in use. The Safety Grille is the related equipment of this product. The explosion-proof type is intrinsically safe. Explosion Proof Mark: [Exia Ga] IIC, power supply voltage 24V DC, short circuit current 100mA, working current (4 ~ 20)mA.

All cables shall be shielded with a maximum length of 500m from instrument to Grille. $U_i=30VDC$, $I_i=100mA$, $P_i=0.75W$, $C_i=0\mu F$, $L_i=0mH$. The radar level transmitter must be connected to the earth when it is installed. No other associated equipment without explosion proof inspection shall be used.

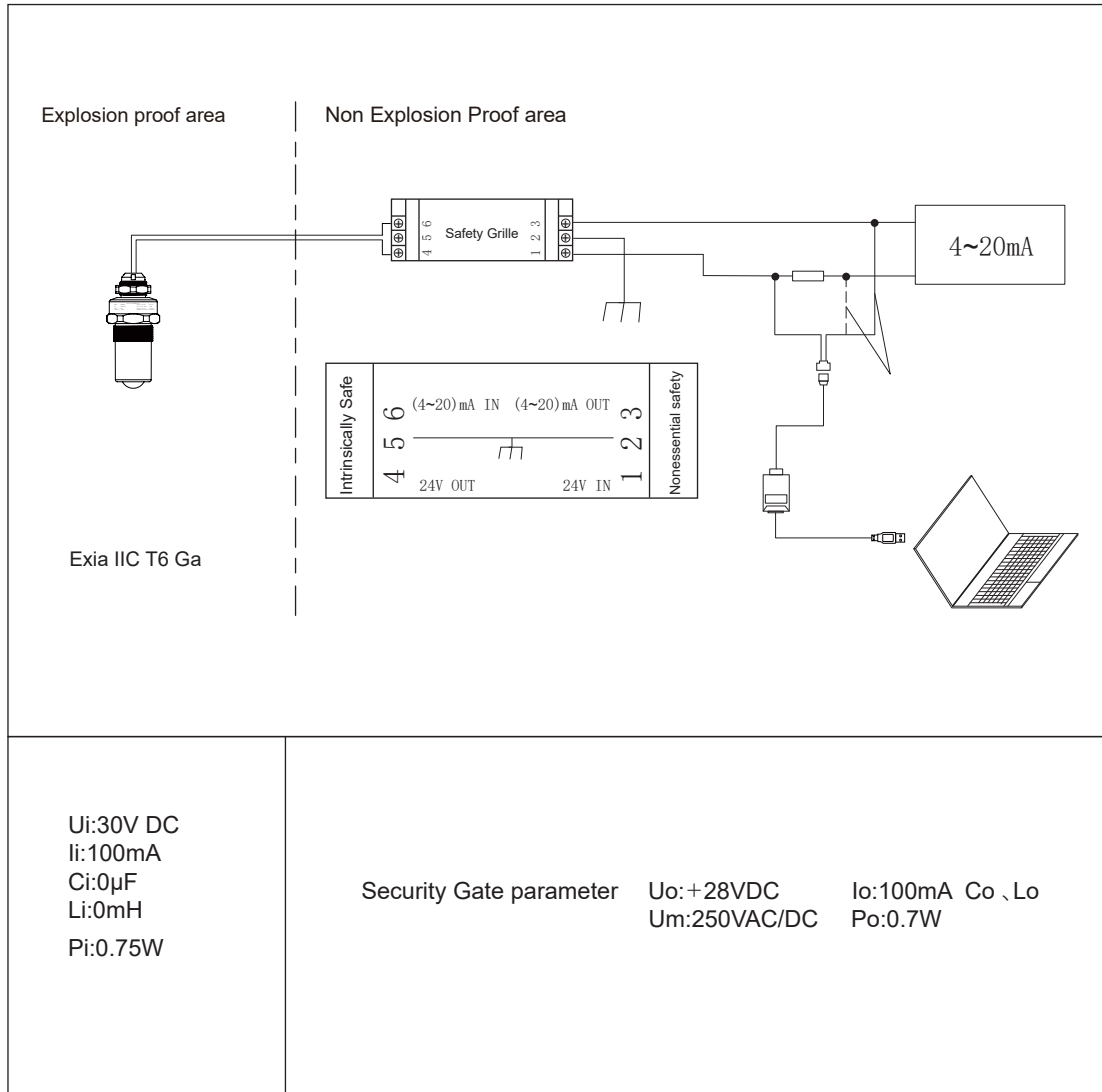

The distribution parameters of the connecting cables between the Grille and the level meter shall satisfy:

$$U_o \leq U_i \quad I_o \leq I_i \quad P_o \leq P_i \quad C_o \geq C_c + C_i \quad L_o \geq L_c + L_i$$

Note: U_o: Maximum output voltage of security gate

I_o: Maximum output current of safety gate

C_o: Maximum external capacitance of security gate

L_o: Maximum External inductance of Safety Grille

C_c: Maximum allowable distributed capacitance of connecting cable

L_i: Maximum internal inductance of level gauge

L_c: Maximum allowable distributed inductance of connecting cable

C_i: Maximum internal capacitance of level meter

5. Technical parameter

General data

Model No.	MDRA5
Process connection	G1½"A
Weight	200g
Process temperature	-40~80 °C
Material	ABS/PVDF

Supply Voltage	Two wire system	Standard type	16~26V DC
		Intrinsic Safety type	21.6~26.4V DC
		Power consumption	Max.0.54W
		Allowable ripple	-<100Hz U _{ss} <1V -(100~100k)Hz U _{ss} <10mV
Cable parameter	Cable diameter	6mm	
Output parameter	Output Signal	4~20mA/HART	
	Resolution	1.6μA	
	Fault output	20.5mA;22mA;3.9mA	
	Damping time	0~100s Adjustable	

Characteristic parameter

Measuring range	8m/15m	
Precision	±2mm	
Blind area	0.05m	
General parameter	Microwave frequency	77~81GHz
	Communication interface	HART
	Measurement interval	About 1 second (depending on the parameter setting)
	Adjustment Time	About 1 second (depending on the parameter setting)
	Vibration resistance	Mechanical Vibration 10m/s ² , (10 ~150)Hz
	Non-repeatability	≤1mm (Has been included in the measurement deviation)
	Relative humidity	<95%

6.Debugging

PC software debugging

(1) Connect with host computer via HART

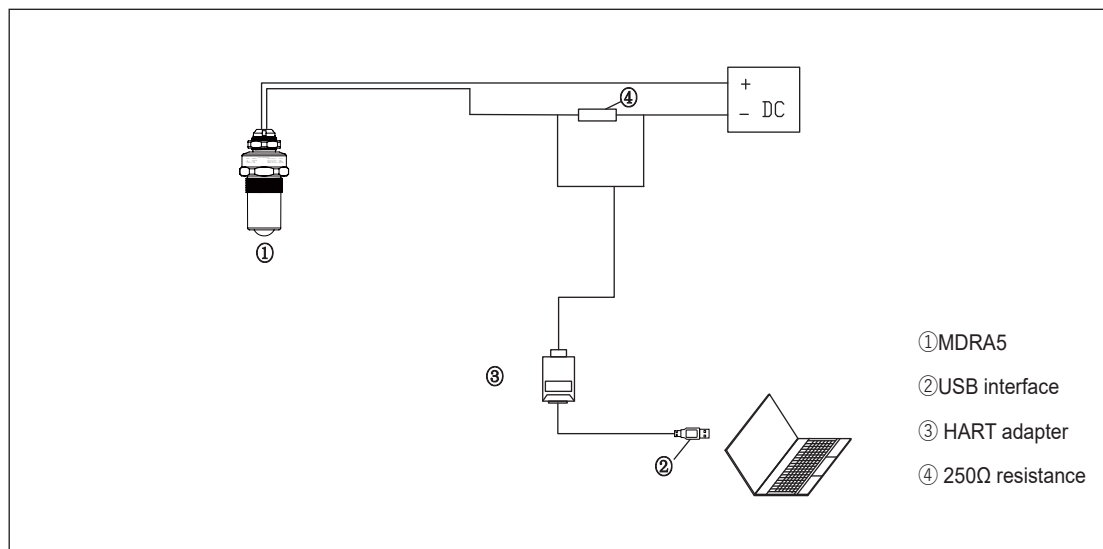

Figure 11

(2) HART handheld programmer debugging

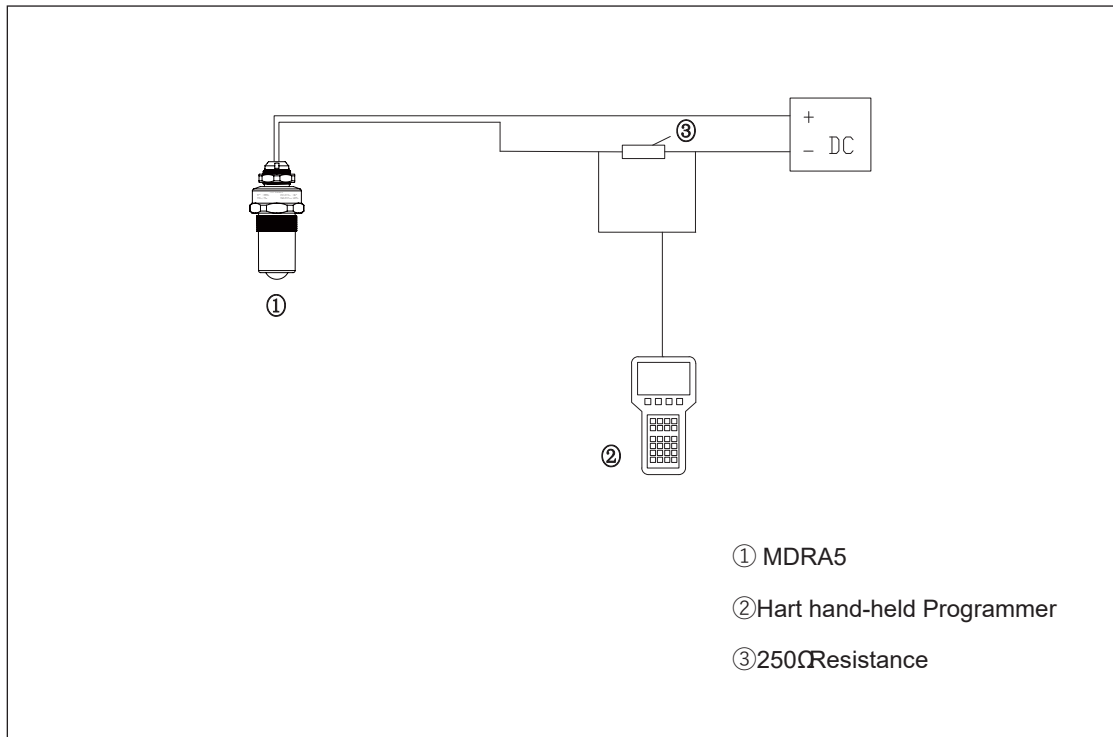

Figure 12

(3) Bluetooth debugging

The MDRA5 can be debugged with Bluetooth capabilities

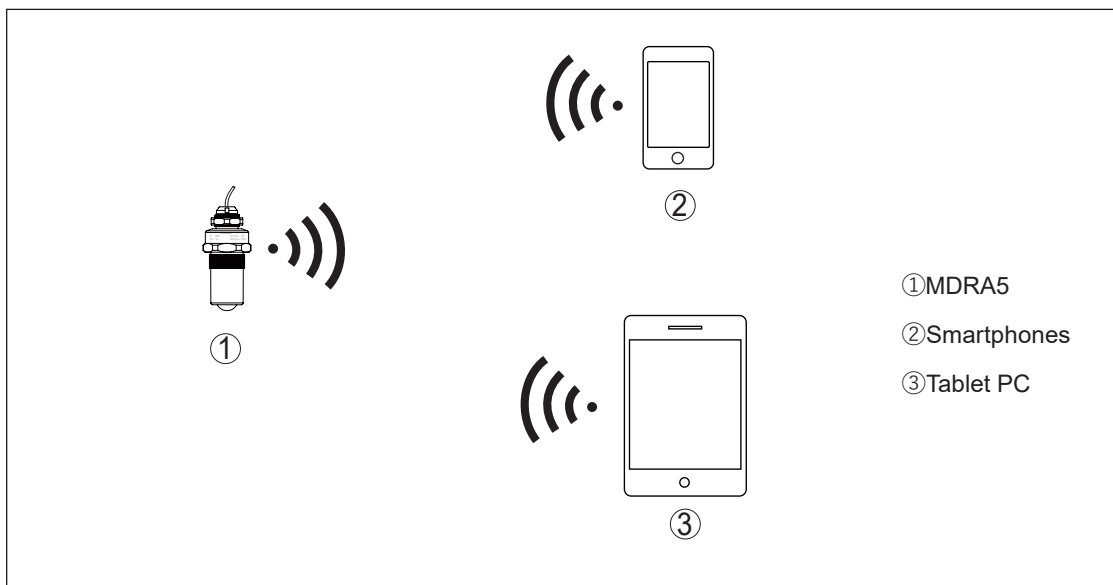
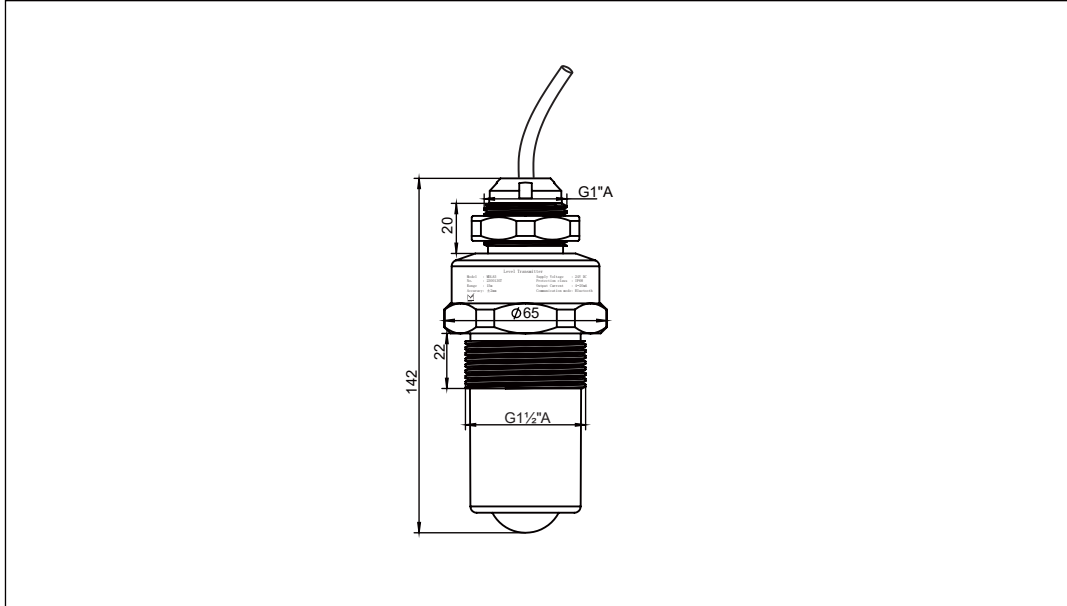
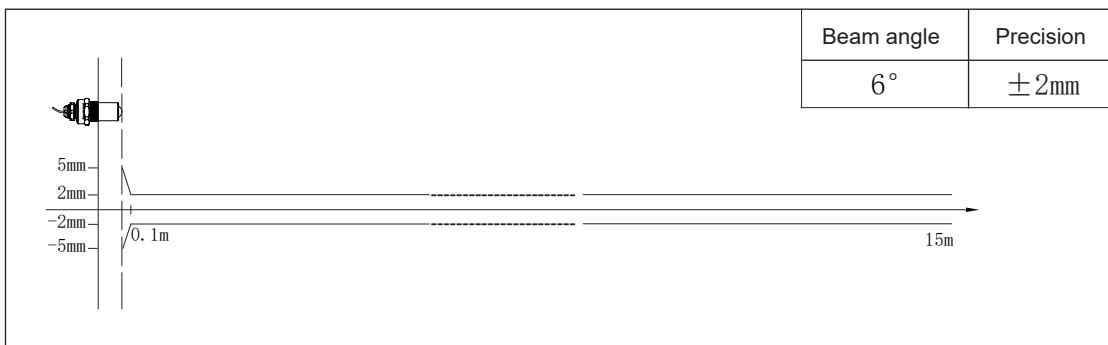
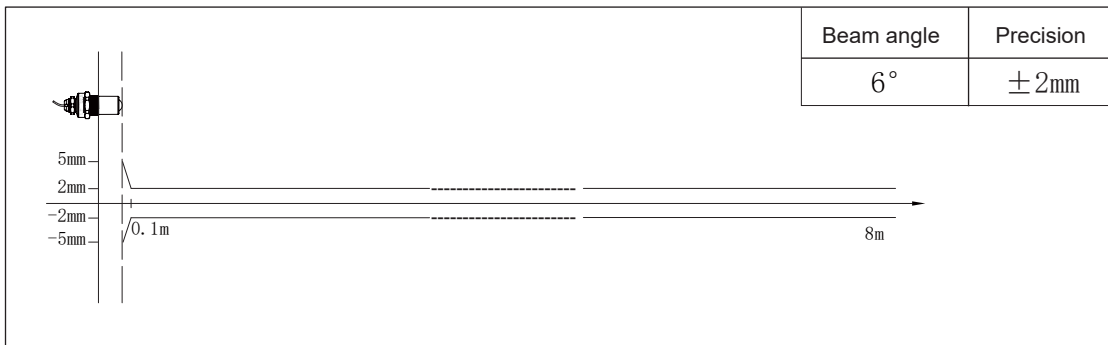

Figure 13

7.Product Structure Dimensions (unit: mm)



8.Linear graph



9. Transport and storage

In addition the transport and storage conditions of level meter shall be in accordance with the following requirements:

1. The material level transmitter should be transported strictly according to the characteristics of the products and the requirements of the specifications.
2. The level gauge shall be stored in a dry ventilated room at (-20 ~ 60) °C with a relative humidity of not more than 80% . Not to be mixed with corrosive substances. After long-term storage of the instrument should be carried



Address: 7191 Yonge street, Toronto, Canada

Tel: +16472221281(5 line)

Web: www.madecotech.com

Email: Info@madecotech.com